

CUSTOMER:	S110176	
DESCRIPTION:	UU9.8 LINE FILTER	REF NO :

VERSION : B | **PAGE : 1/2**

SPECIFICATION

Compliant RoHS

I .PHYSICAL DIMENSIONS (Unit:mm)

A	B	C	D	L	P1	P2
16.5 max	11.5max	17.5 max	Ø0.6±0.1	4.0±1.0	8.0±0.5	7.0±0.5

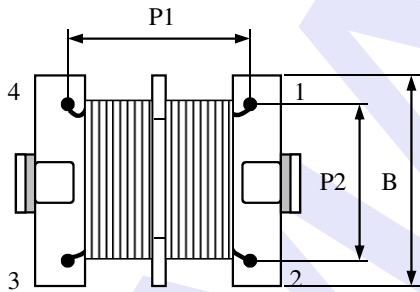
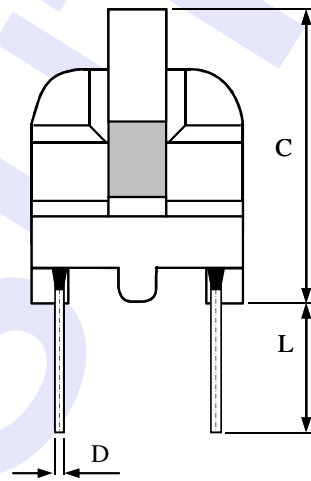
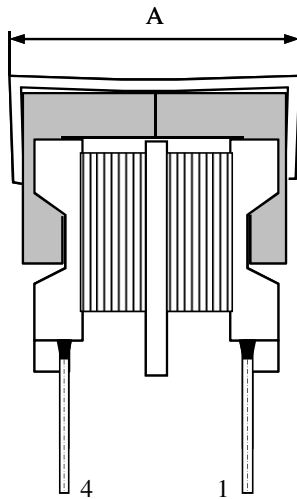

Bottom View

II . WINDING DIAGRAM

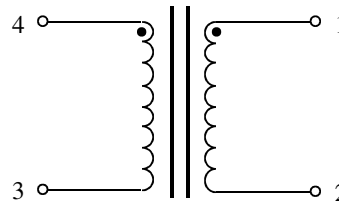

Note: ● Winding start

APP	CHK	DRG
钟明德	王成锋	彭小运

SAMPLE NO.	
MATSUTA NO.	63-169818002Q
SPEC. NO.	TR18002
ISSUE DATE.	2011-9-3

MATSUTA CO.,LTD.

Flat 15, 10/F, Block B, Tonic Industrial Centre,
19 Lam Hing Street, Kowloon Bay, Hong Kong.

Tel: (852) 2796 6693

Fax: (852) 2796 3530, 2754 5674

E-mail: matsuta@matsuta.com.hk

Web site: <http://www.matsuta.com>

CUSTOMER:		REF NO:	S110176
DESCRIPTION:	UU9.8 LINE FILTER	VERSION: B	PAGE: 2/2

SPECIFICATION

Compliant RoHS

III. ELECTRICAL PERFORMANCE

C.D.	N(Ts)	WIRE 2UEW	START	END	INDUCTANCE	DC RESIST
N1	168	Ø0.18mm	1	2	28mH min	3.2 Ω max
N2	168	Ø0.18mm	4	3	28mH min	3.2 Ω max
N O T E	1. Inductance measured by CH-100LCR (at 1KHz/0.25V).					
	2. DC Resist measured by CH-502AC (at 25°C).					
	3. HI-POT test: Coil to Coil 1.2KV/AC/3mA for 2seconds. Coil to Core 1.2KV/AC/3mA for 2seconds.					

IV. MATERIALS LIST:

NO	ITEM	MATERIALS	MANUFACTURER	UL FILE NO
1	BOBBIN	PY-0902 UU9.8 PHENOLIC T375J 94V-0	PIN YUE Plastic Products Co., Ltd.	E59481(S)
2	CLIP	SUS-301	CHUANG SHUN ELECTRONIC	N/A
3	CORE	P7K UU9.8	PANSCIENCE (SHENZHEN MAXMAGTECH CO.,LTD)	N/A
		R7k UU9.8	DMEGC	N/A
4	WIRE	2UEW 130°C	FENG CHING METAL CORP	E172395
5	VARNISH	1032BOH	QUALIPOLY CHEMICAL CORP	E213437
6	SOLDER	SMD1	NIHON GENMA (matsuta)	N/A

APP	CHK	DRG	SAMPLE NO.	
钟明德	王成锋	彭小运	MATSUTA NO.	63-169818002O
			SPEC. NO.	TR18002
			ISSUE DATE.	2011-9-3

MATSUTA CO.,LTD.

Flat 15, 10/F, Block B, Tonic Industrial Centre,
19 Lam Hing Street, Kowloon Bay, Hong Kong.

Tel: (852) 2796 6693

Fax: (852) 2796 3530, 2754 5674

E-mail: matsuta@matsuta.com.hk

Web site: http://www.matsuta.com