

CUSTOMER:		REF NO: S110268
DESCRIPTION:	UU9.8 LINE FILTER	VERSION:A PAGE:1/2

SPECIFICATION

Compliant RoHS

I .PHYSICAL DIMENSIONS (Unit:mm)

A	B	C	D	L	P1	P2
17 max	12 max	17.5 max	Ø0.6±0.1	4.0±1.0	8.0±0.5	7.0±0.5

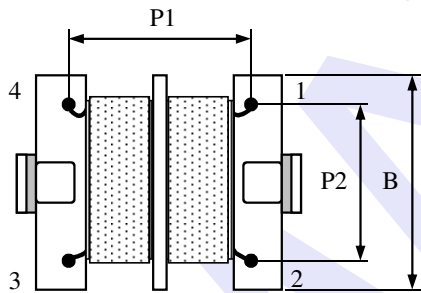
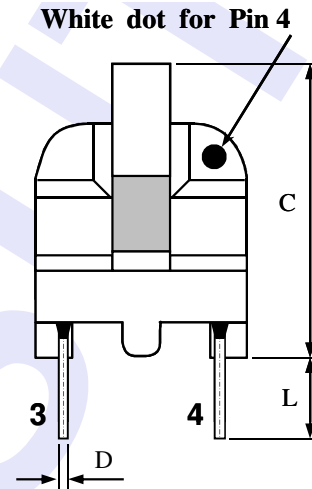
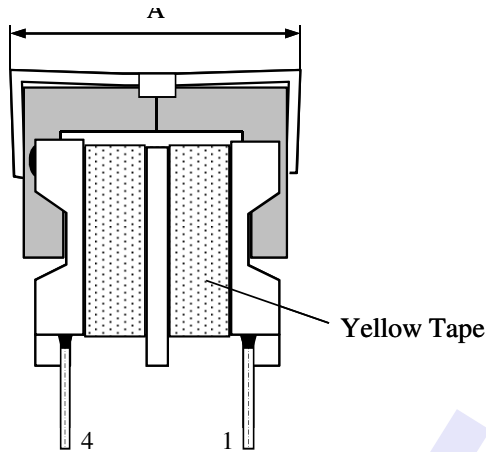

Bottom View

II . WINDING DIAGRAM

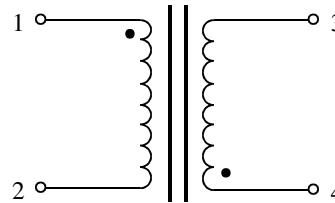

Note: ● Winding start

APP	CHK	DRG
钟明德	王成锋	彭小运

SAMPLE NO.	
MATSUTA NO.	63-169818260
SPEC. NO.	TR18260
ISSUE DATE.	2011-12-1

CUSTOMER:	REF NO : S110268		
DESCRIPTION:	UU9.8 LINE FILTER	VERSION : A	PAGE : 2/2

SPECIFICATION

Compliant RoHS

III. ELECTRICAL PERFORMANCE & CONSTRUCTION

C.D.	START	END	N(Ts)	WIRE (UEW)	INDUCTANCE	DC RESIST
N1	1	2	120 Ref	ø0.21mm	25mH min	3 Ω max
N2	4	3	120 Ref	ø0.21mm	25mH min	3 Ω max
N O T E	1. Inductance measured by CH-100LCR (1KHz/0.25V).					
	2. DC Resist measured by CH-502AC (at 25°C).					
	3. HI-POT test: Coil to Coil 1500V/AC/3mA for 2seconds. Coil to Core 1500V/AC/3mA for 2seconds.					

IV. MATERIALS LIST:

NO	ITEM	MATERIALS	MANUFACTURER	UL FILE NO
1	BOBBIN	UU9.8 PHENOLIC T375J 94V-0	CHANG CHUN PLASTICS CO.,LTD.	E59481(S)
2	CORE	A10 UU9.8 OR EQUIVALENT	ACME ELECTRONICS CO.,LTD. OR EQUIVALENT	N/A
3	WIRE	UEW 130°C	FENG CHING METAL CORP OR EQUIVALENT	E172395
4	CLIP	UU9.8	CHUANG SHUN ELECTRONIC	N/A
5	TAPE	CT280 P2068F	JINGJIANG YAHUA PRESSURE SENSITIVE GLUE CO LTD or CHYUN YIH TAPE CO.,LTD	E165111 E81174
6	VARNISH	1032BIH	QUALIPOLY CHEMICAL CORP	E213437
7	SOLDER	SMD1	NIHON GENMA	N/A

APP	CHK	DRG	SAMPLE NO.	
钟明德	王成锋	彭小运	MATSUTA NO.	63-169818260
			SPEC. NO.	TR18260
			ISSUE DATE.	2011-12-1

MATSUTA CO.,LTD.

Flat 15, 10/F, Block B, Tonic Industrial Centre,
19 Lam Hing Street, Kowloon Bay, Hong Kong.

Tel: (852) 2796 6693

Fax: (852) 2796 3530, 2754 5674

E-mail: matsuta@matsuta.com.hk

Web site: <http://www.matsuta.com>