

CUSTOMER:		REF NO :	S100206
DESCRIPTION:	UU10.5 LINE FILTER	VERSION:A	PAGE: 1/2

SPECIFICATION

Compliant RoHS

I .PHYSICAL DIMENSIONS (Unit:mm)

A	B	C	D	L	P1	P2
19.0 max	17.0 max	22.0 max	Ø0.7±0.1	3.5±1.0	13.0±0.5	10.0±0.5

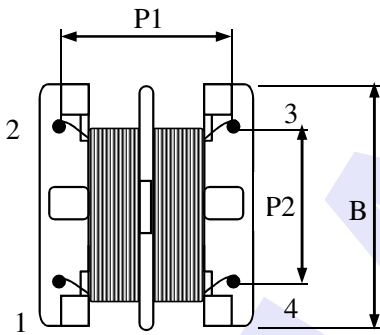
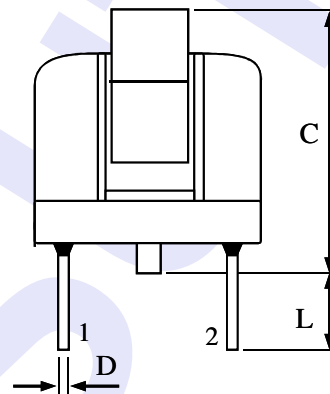
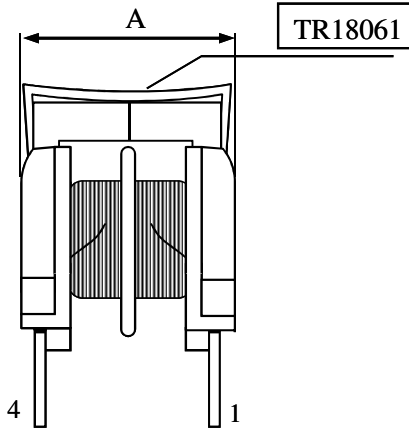

BOTTOM VIEW

II . WINDING DIAGRAM

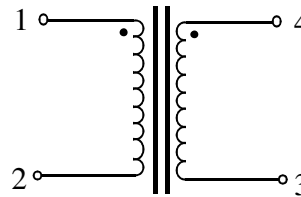

Note: ● Winding start

APP	CHK	DRG

SAMPLE NO.	
MATSUTA NO.	63-1A2018061Q
SPEC. NO.	TR18061
ISSUE DATE.	2011-9-10

MATSUTA CO.,LTD.

Flat 15, 10/F, Block B, Tonic Industrial Centre,
19 Lam Hing Street, Kowloon Bay, Hong Kong.

Tel: (852) 2796 6693

Fax: (852) 2796 3530, 2754 5674

E-mail: matsuta@matsuta.com.hk

Web site: <http://www.matsuta.com>

CUSTOMER:	REF NO :S100206		
DESCRIPTION:	UU10.5 LINE FILTER	VERSION : A	PAGE : 2/2

SPECIFICATION

Compliant RoHS

III.ELECTRICAL PERFORMANCE

C.D.	Ts (REF)	WIRW (UEW)	START	END	DCR	INDUCTANCE
N1	50	Ø0.45mm	1	2	230mΩmax	7mH min
N2	50	Ø0.45mm	4	3	230mΩmax	7mH min
NOTE	1. Inductance measured by CH-1061LCR (at 10KHz/1V).					
	2. HI-POT test:Coil to Coil 2000V/AC/1mA for2 seconds.					

IV、 MATERIALS LIST:

NO	ITEM	MATERIALS	MANUFACTURER	UL FILE NO
1	BOBBIN	PHENOLIC T375J 94V-0 (UU-10.5)	CHANG CHUN PLASTICS CO.,LTD. (PIN SHINE ELECTRONICS INTERNATIONAL CO., LTD.)	E59481
2	CLIP	SUS-301 UU10.5	CHUANG SHUN ELECTRONIC	N/A
3	CORE	A121 UU10.5	ACME Electronics Corporation	N/A
4	WIRE	UEW 130°C	FENG CHING METAL CORP	E172395
5	SOLDER	MG-101G	NIHON GENMA	N/A

APP	CHK	DRG

SAMPLE NO.	
MATSUTA NO.	63-1A2018061Q
SPEC. NO.	TR18061
ISSUE DATE.	2011-9-10

MATSUTA CO.,LTD.

Flat 15, 10/F, Block B, Tonic Industrial Centre,
19 Lam Hing Street, Kowloon Bay, Hong Kong.

Tel: (852) 2796 6693

Fax: (852) 2796 3530, 2754 5674

E-mail: matsuta@matsuta.com.hk

Web site: <http://www.matsuta.com>